

QJC Quick Jaw Change Chuck



Application / Benefits

- Minimal set-up times ; change jaws within a minute
- Reversible jaws
- High repeatability of < 0.02mm
- No reboring required

Technical features

- Wedge bar system minimizes loss of gripping force
- Built-in safety feature ensures jaw serration engagement

ACTUAL GRIPPING FORCE DIAGRAM

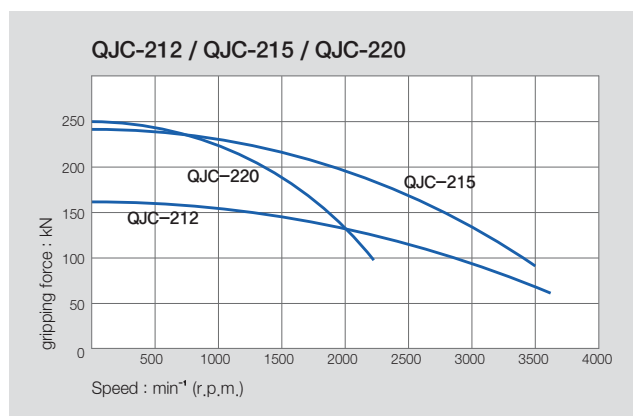
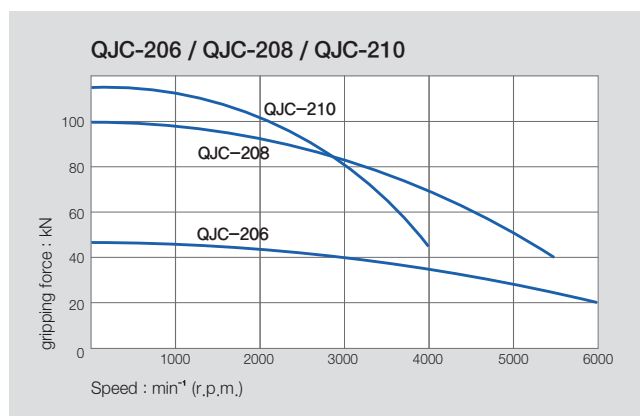

SPECIFICATIONS

	QJC-206	QJC-208	QJC-210	QJC-212	QJC-215	QJC-220
Jaw Stroke Dia. [mm]	11.4	14.4	16	16	17	20
Plunger Stroke [mm]	20	25	28	28	32	42
Permissible Input Force [kN(kgf)]	30(3059)	54(5404)	65(6628)	90(9177)	133(13562)	120(12236)
Max.static Gripping Force [kN(kgf)]	45(4538)	100(10197)	115(11726)	160(16315)	240(24473)	250(25492)
Max. r.p.m. [min ⁻¹]	6000	5500	4000	3600	3500	2200
Weight [kg]	13	24	42	66	109	225
Moment of inertia [kg · m ²]	0.11	0.11	0.41	0.97	2.3	6.5
Operating Cylinder	SD-13546	SD-17568	SD-18582	SD-21511	SDL-25411	SDL-30516
Max. Hydraulic Pressure [MPa(kgf/cm ²)]	3.0(30.5)	3.0(35.6)	3.7(37.7)	4.0(40.7)	4.0(40.7)	2.9(29.5)

Thru Hole Range : $\varnothing 45 \sim \varnothing 155$
Clamping Range : $\varnothing 15 \sim \varnothing 400$

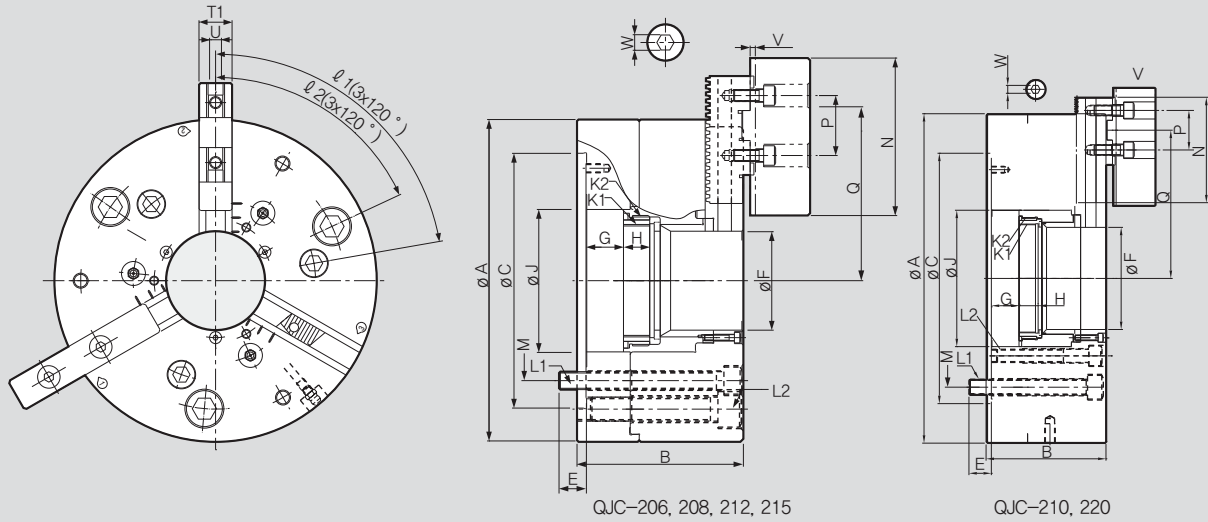

※ It is recommended to grease chucks at least twice a day in order to maximize longevity.

DIMENSIONS

	QJC-206	QJC-208	QJC-210	QJC-212	QJC-215	QJC-220
ΦA	165	215	260	315	400	500
B	95	111	129.3	138.1	144	182
ΦC (기준경)	140	170	220	220	300	380
E	14	18	23.7	24.9	25	34
ΦF	45	66	81	104	128	155
G max.	20.2	25	28	28.5	32	42
G min.	0	0	0	0	0	0
H	15	17.5	22	23.2	22	29
ΦJ	68	95	114	148	180	207
K1	M50	M75	M90	M115	M138	M165
K2	M60	M87	M105	M135	M160	M185
L1	3-M10	3-M12	3-M16	3-M16	3-M20	3-M24
L2	3-M12	3-M16	3-M12	3-M20	3-M24	3-M20
i_1	80°	80°	80°	80°	70°	85°
i_2	20°	65°	65°	70°	60°	75°
M	104.8	133.35	171.4	171.4	235	330.2
N	85	97	125	125	145	160
P	32	40	40	40	54	60
Q max.	76.8	118.3	129.7	159.1	182.4	225
Q min.	58	71.2	102.2	106.9	121.9	141
T1	20	22	30	30	35	45
T2	20	22	26	32	32	48
U	8	10	12	12	12	18
V	2.5	2.5	3	3	3	4
W	8	10	10	10	10	12

※ Blank and machined draw-nuts are available.

RELATED PRODUCT

