

# HST / HSF 2-Jaw, 4-Jaw High-Speed Open Center Chuck



## Application / Benefits

For square or rectangular parts requiring a through-hole

## Technical features

Wedge hook style chuck with high gripping force

## ACTUAL GRIPPING FORCE DIAGRAM

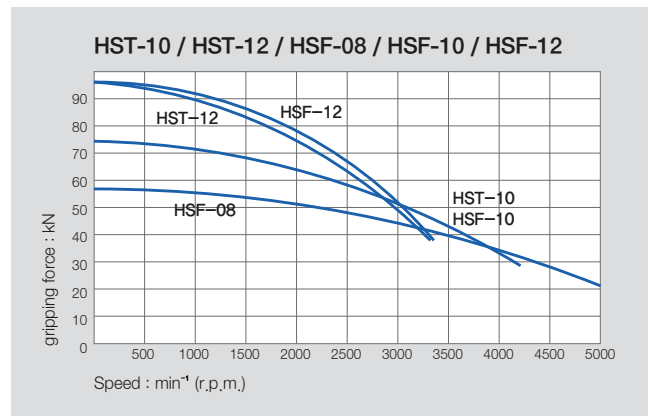
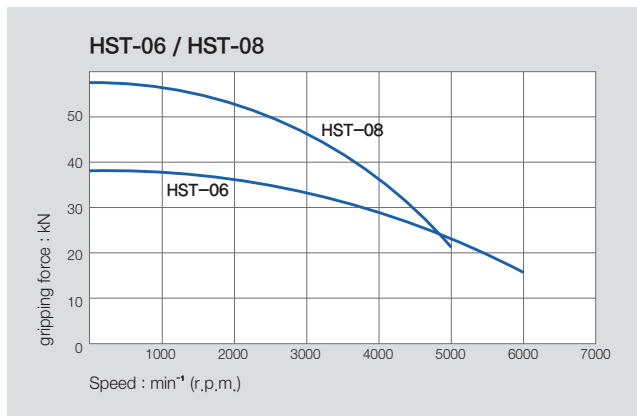

## SPECIFICATIONS

	HST-06	HST-08	HST-10	HST-12	HSF-08	HSF-10	HSF-12
Thru Hole Dia. [mm]	46	52	77	91	52	77	91
Grip Dia. Max [mm]	169	210	254	304	210	254	304
Grip Dia. Min [mm]	15	13	31	34	13	31	34
Jaw Stroke Dia. [mm]	5.5	7.4	8.8	10.6	7.4	8.8	10.6
Plunger Stroke [mm]	12	16	19	23	16	19	23
Max. Permissible Input Force [kN(kgf)]	14.5 (1479)	23.2 (2366)	28.5 (2906)	36.7 (3742)	23.2 (2366)	28.5 (2906)	36.7 (3742)
Max. Static Gripping Force [kN(kgf)]	38 (3875)	57.3 (5843)	74 (7546)	96 (9789)	57.3 (5843)	74 (7546)	96 (9789)
Max. r.p.m. [min <sup>-1</sup> ]	6000	5000	4200	3300	5000	4200	3300
Weight [kg]	11.5	21.3	33.5	52	22.5	34.5	52
Moment of inertia [N · m <sup>2</sup> (kg · m <sup>2</sup> )]	2.21 (0.225)	6.47 (0.66)	12.06 (1.23)	27.46 (2.8)	6.67 (0.68)	12.08 (1.24)	27.42 (2.8)
Operating Cylinder	SH-13046 (SYH-1246)	SH-15052 (SYH-1552)	SH-18077 (SYH-1877)	SYH-2091	SH-15052 (SYH-1552)	SH-18077 (SYH-1877)	SYH-2091
Max. Hydraulic Pressure [MPa(kgf/cm <sup>2</sup> )]	1.85 (18.9)	1.80 (18.4)	1.80 (18.4)	1.81 (18.5)	1.80 (18.4)	1.80 (18.4)	1.80 (18.5)
KITAGAWA® Model	BT-206	BT-208	BT-210	BT-212	-	-	-

※ Maximum turning speed is based upon actual measurement.

※ Samchully Machinery Co., Ltd. is no longer an OEM manufacturer for Kitagawa® Iron Works Co., Ltd.

Thru Hole Range :  $\varnothing 46 \sim \varnothing 91$   
Clamping Range :  $\varnothing 15 \sim \varnothing 304$

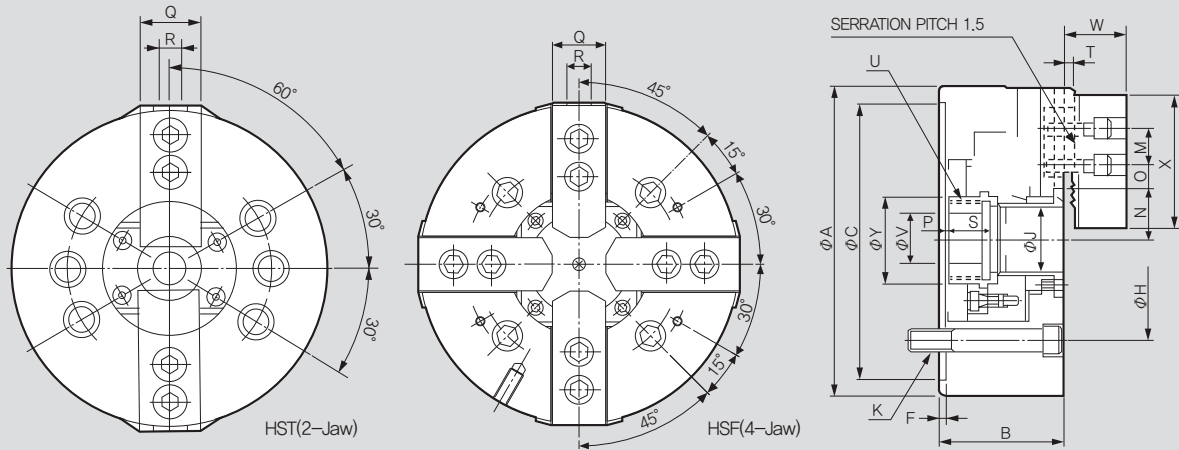

※ It is recommended to grease chucks at least twice a day in order to maximize longevity.

## DIMENSIONS

	HST-06	HST-08	HST-10	HST-12	HSF-08	HSF-10	HSF-12
ΦA	169	210	254	304	210	254	304
B	81	91	100	110	91	100	110
ΦC(H6)	140	170	220	220	170	220	220
F	5	5	5	6	5	5	5
ΦH	104.8	133.4	171.4	171.4	133.4	171.4	171.4
ΦJ	46	52	77	91	52	77	91
K	6-M10x95	6-M12x105	6-M16x100	6-M16x110	4-M10x105	4-M12x120	4-M16x130
M	20	25	30	30	25	30	30
N max.	32	38.7	51	61.3	38.7	51	61.3
N min.	29.25	35	46.6	56	35	46.6	56
O max.	22.75	30	34	45.75	29.75	33.75	45.75
O min.	9.25	15	14.5	15.75	14.75	14.25	15.75
P min	-1	-1.5	-10.5	-15	-1.5	-11	-15
P max	11	14.5	8.5	8	14.5	8.5	8
Q	31	35	40	49	35	40	49
R	12	14	16	21	14	16	21
S	19	20.5	25	28	20.5	25	28
Y	2	2	2	2	2	2	2
U max.	M55x2.0	M60x2.0	M85x2.0	M100x2.0	M60x2.0	M85x2.0	M100x2.0
ΦV	20	30	45	50	30	45	50
W	29	39	43	50.5	39	43	50.5
X	66	95	110	111	95	110	111
ΦY	60	66	94	108	66	94	108

※ Blank and machined draw-nuts are available.

RELATED PRODUCT

