

AN1

Gripping range	6-70 mm
Cylinder size	40 mm
Total max gripping force	250 daN
Max peripheral roller speed	730 m/min
Centering accuracy*	0,02 mm
Repeatability	0,005 mm
Standard operating pressure	10 bar
Max operating pressure	20 bar
Mounting holes**	Same as SLU-1

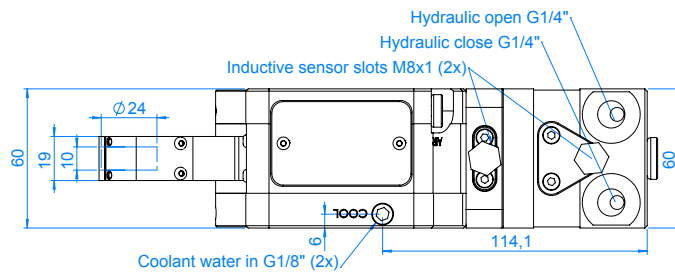
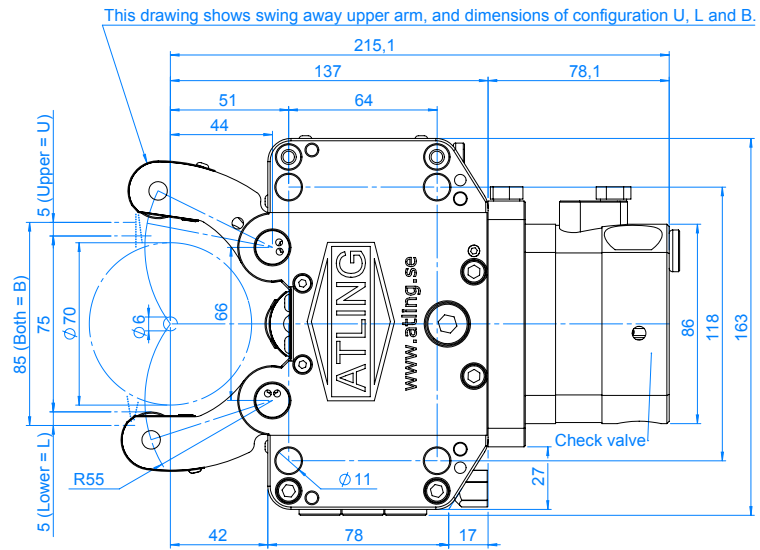

AN2

Gripping range	8-105 mm
Cylinder size	50 mm
Total max gripping force	785 daN
Max peripheral rollerspeed	930 m/min
Centering accuracy*	0.02 mm
Repeatability	0.005 mm
Min operating pressure	10 bar
Max operating pressure	40 bar
Mounting holes**	Same as SLU-2

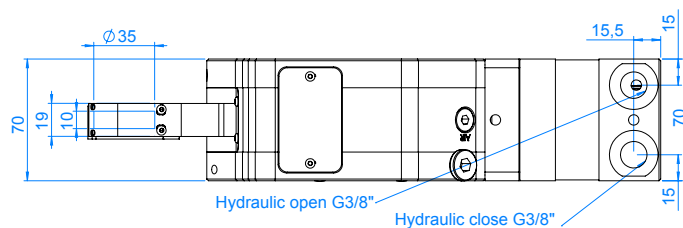
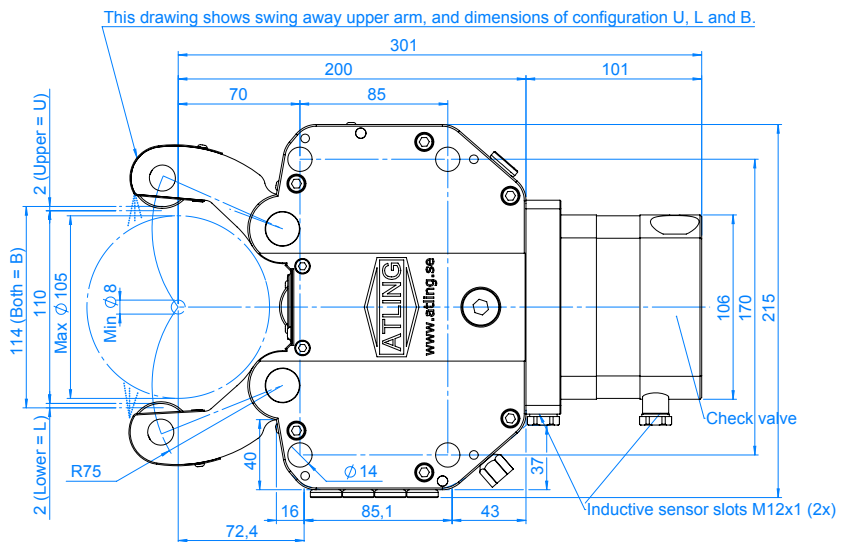

*At constant pressure and clamping force, 20 bar.

** Note: Same hole pattern, can interfere on the bracket. Check drawings.

AN3

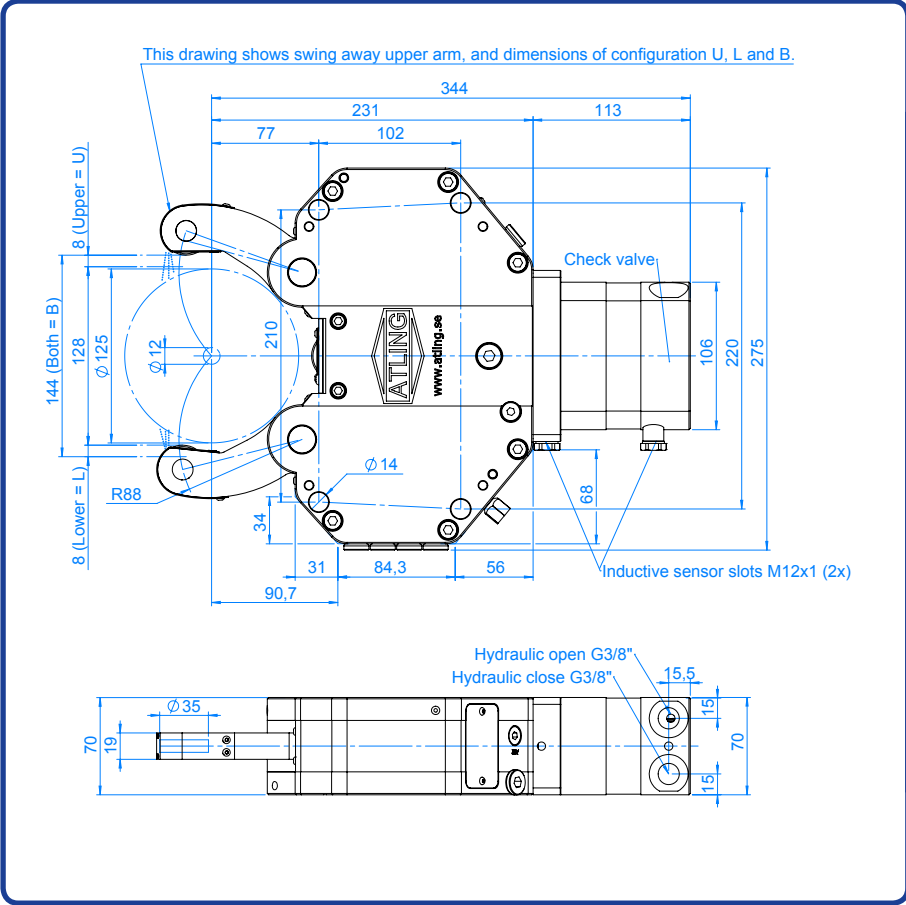

Gripping range	12-125 mm
Cylinder size	50 mm
Total max gripping force	785 daN
Max peripheral rollerspeed	930 m/min
Centering accuracy*	0.04 mm
Repeatability	0.005 m
Min operating pressure	10 bar
Max operating pressure	40 bar
Mounting holes**	N/A

AN4

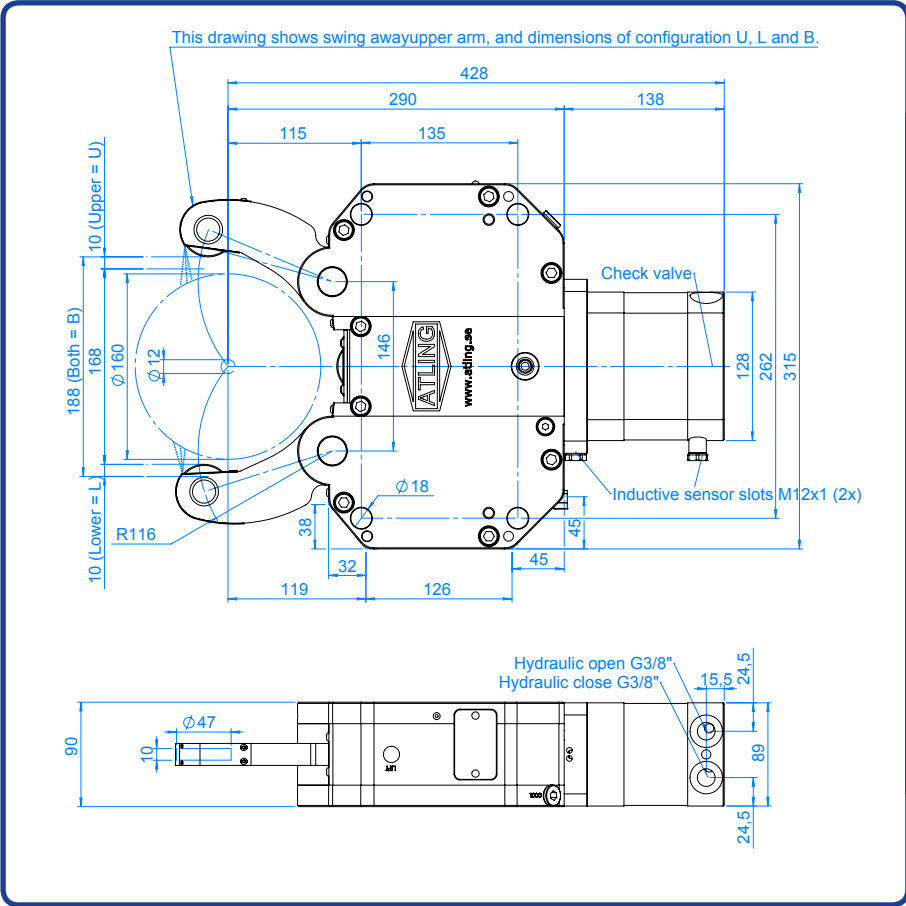

Gripping range	12-160 mm
Cylinder size	80 mm
Total max gripping force	2010 daN
Max peripheral rollerspeed	805 m/min
Centering accuracy*	0.04 mm
Repeatability	0.005 mm
Min operating pressure	10 bar
Max operating pressure	40 bar
Mounting holes**	Same as SLU-3

*At constant pressure and clamping force, 20 bar.
 ** Note: Same hole pattern, can interfere on the bracket.
 Check drawings.